

Field Engineering

Maintenance Manual

Restricted Distribution

This manual is intended for internal use only and may not be used by other than IBM personnel without IBM's written permission .

Specifications contained herein are subject to change without notice. Revisions and/or supplements to this publication will be issued periodically.

1442

Card Read Punch

Models 5, 6, and 7

PREFACE

This manual provides the service and maintenance information for the IBM 1442 Card Read Punch, Models 5, 6, and 7.

Adjustment and removal procedures for above-base mechanical units of the serial reader punch are explained in the IBM Field Engineering Maintenance Manual, Serial Reader Punch, Form 231-0026.

RESTRICTED DISTRIBUTION: This publication is intended for use by IBM personnel only and may not be made available to others without the approval of local IBM management.

This edition, Form Y31-0098-1, obsoletes the previous edition Form 231-0098-0. Logic references and adjustment procedures have been updated.

Technical changes are indicated by a line at the left of the text; altered figures are indicated by a bullet (●) ahead of the figure caption.

A form is included at the back of this manual for readers' comments. If this form has been removed, address comments to: IBM Corporation, Product Publications, Dept. 245, Rochester, Minn. 55901.

CONTENTS

CHAPTER I. DIAGNOSTIC AIDS	1-1	Adjustment Objectives	4-2
Section 1. Diagnostic Techniques	1-1	Adjustment Procedure	4-2
General Procedures	1-1	Card Feed Emitter	4-3
Card Examination	1-1	Service Check	4-3
Operator Console Error Indications	1-1	Adjustment Objectives	4-4
Section 2. Service Aid Index	1-3	Adjustment Procedure	4-4
Section 3. Service Aids	1-5	Punch Emitter	4-4
		Adjustment Objectives	4-4
CHAPTER II. MAINTENANCE FEATURES	2-1	Adjustment Procedure	4-4
Diagnostic Programs	2-1	Incremental Drive Emitter	4-5
CE Switch	2-1	Adjustment Objectives	4-5
Lamp Test	2-1	Adjustment Procedure	4-5
Data Pulse Switch	2-1	Punch Hold Coil Voltage	4-6
		Adjustment Objective	4-6
CHAPTER III. PREVENTIVE MAINTENANCE		Adjustment Procedure	4-6
PROCEDURES	3-1	Light Source Lamp Voltage, Models 6 and 7	4-6
Approach to Scheduled Maintenance	3-1	Adjustment Objective	4-6
		Adjustment Procedure	4-6
CHAPTER IV. CHECKS AND ADJUSTMENTS	4-1	Light Source Lamp Voltage, Model 5	4-8
Mechanical Adjustments and Removals	4-1	Adjustment Objective	4-8
Card Feed Clutch Response Service Check	4-1	Adjustment Procedure	4-8
Objective	4-1		
Procedure	4-1	CHAPTER V. POWER SUPPLIES	5-1
Read Clutch Response Service Check, Models		1442 Model 5	5-1
6 and 7	4-1	DC Power Supply	5-1
Objective	4-1	Use Meter Transformer	5-1
Procedure	4-1	Power Supply	5-1
Read Data Pulse Service Check, Models 6 and 7	4-2	Use Meter Transformer	5-1
Objective	4-2		
Procedure	4-2	CHAPTER VI. LOCATIONS	6-1
Read Emitter Timing and Duration			
Models 6 and 7	4-2		
Service Check	4-2	Index	X-1

SAFETY

PERSONAL SAFETY

Ensure your own safety by using caution at all times, and by being aware of potentially dangerous areas of the machine. Read and follow the safety suggestions in Form 229-1264, a pocket-sized card issued to all IBM Customer Engineers.

Remember:

- Loose clothing can become entangled in moving parts of the machine.
- Drive belts, because of their internal cable construction, can cause serious injury. DO NOT crank a machine by pulling on the drive belts.
- Heat sinks are at an electrical potential. DO NOT short heat sinks to each other or to the machine side frame.
- Always unplug machine power and wait ONE FULL MINUTE before attempting repairs or adjustments in the power supply area.
- Voltages developed in the resonant circuit of regulating power supplies are apt to be much greater than line voltages.
- Follow the specific safety precautions that accompany many of the adjustment procedures in this manual.

EQUIPMENT SAFETY

Electrical

Always replace blown fuses with fuses of the same type and rating. Using fuses of a different type or higher rating could result in component damage in case of shorting or overloads.

Remove power from the machine before replacing SLT cards. Failure to do this could result in damage to the card being replaced or other cards in the net.

Mechanical

Do not operate the SRP mechanism under power with units disassembled, removed, or maladjusted. Keep tools, etc. clear of the SRP when operating under power.

SECTION 1. DIAGNOSTIC TECHNIQUES

General Procedures

A customer normally learns of 1442 failures from the using system, from indicator lights on the operator panel, or from examination of the punched cards. The Customer Engineer is normally called after the customer has verified the failure. At this time, it is well for the CE to gather as much information as possible, such as:

- Which error indications did the customer receive from the using system?
- Which 1442 indicator lights came on?
- Can the failure be duplicated?
- Does the failure tend to stay with one card column; with a particular punch or group of punches?
- Do the failures form a pattern?

If the customer can release the system, the diagnostic programs provided can be used to further isolate the failure.

After a failure has been diagnosed and repaired, the diagnostic programs should be run for a final check of 1442 operation.

Card Examination

Close examination of cards fed through the 1442 is an important step in the diagnostic procedure. In many instances, a failure that turns on an indicator results from something interfering with the normal movement of cards through the feed. Such interference often appears as a mark or nick on the card.

Reading failures can be caused by off-punched cards. It is well to examine (if possible) the cards that were being used at the time of the failure.

Operator Console Error Indications

(Reference Figure 1-1)

All indicators on the 1442 operator console, except the power on and chip box indicators, are directly controlled by the processing unit of the using system.

Indicator Lamps

Power On indicates that both AC and DC power are applied to the 1442. If the light is off, a power failure is indicated.

Ready, normally lighted by the using system's processing unit to indicate that the 1442 has cards in the feed and is ready to process them. If the indicator is off, it implies one or more of the following conditions:

- Power off.
- Card not registered at read or punch station (no card required at punch station on cycle immediately following run-in cycles).
- Hopper empty.
- Stacker full.
- Cover interlock open.
- Chip box full or not in place.
- Attention or check light on.

Chip Box (1442-6 & 7 only) indicates that the chip box is full or not in place.

Attention (1442-5 only) indicates one or both of the following conditions:

- Chip box full or not in place.
- Stacker full.

When the attention light is on, the ready light is off.

Check, turned on by the processing unit, indicates an error condition. The error is further identified by one of the lights on the back-lighted panel.

Back-Lighted Panel Indicators

Hopper indicates that a card did not feed from the hopper during a feed cycle.

Sense Sta (1442-5) or Read Sta (1442-6 & 7) indicates a jam in the read station, or a malfunction in the reading circuits.

Punch Sta indicates a jam at the punch station.

Trans indicates a jam in the stacker transport area.

Feed Clu indicates that an unrequested feed cycle occurred.

Read Reg (1442-6 & 7 only) indicates that two consecutive samplings of data from a card column were unequal.

Punch indicates that the punch echo data did not match the data to be punched.

Overrun (1442-6 & 7 only) indicates that a data handling sequence error was detected by the processing unit.

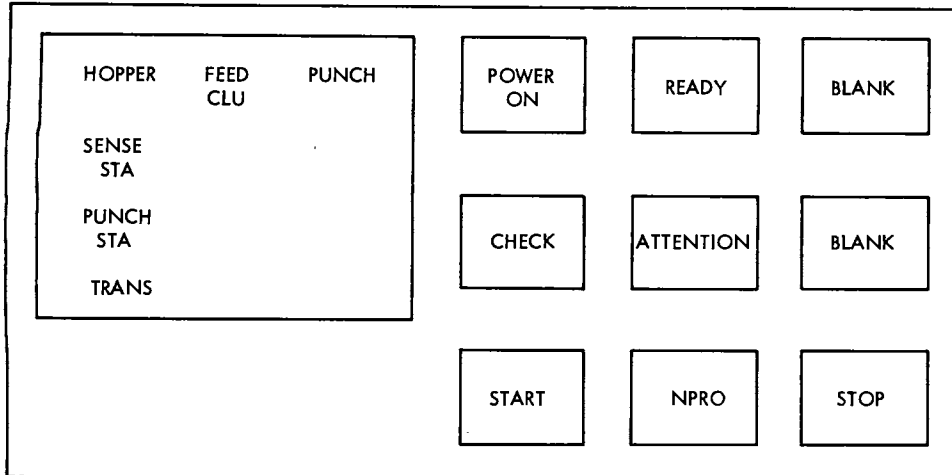

1442 Model 5 Operator Panel

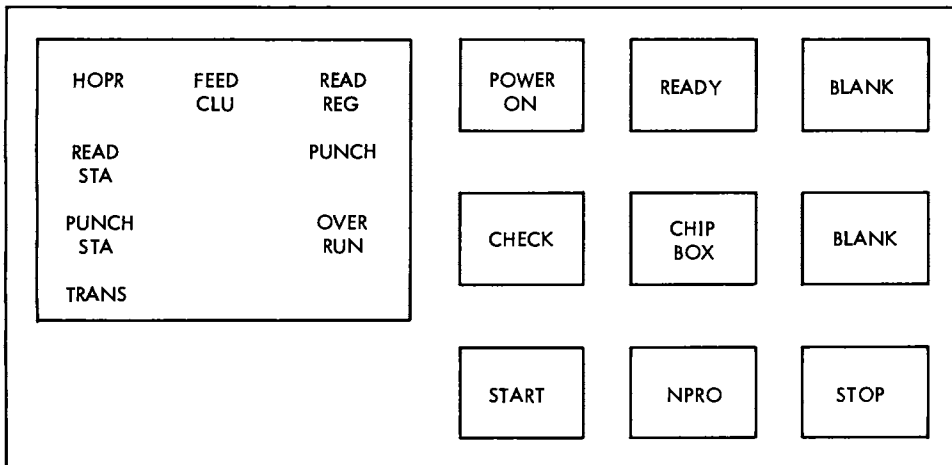

1442 Models 6 & 7 Operator Panel

Figure 1-1. Operator Panels

SECTION 2. SERVICE AID INDEX

Insert service aid index behind this page.

SECTION 3. SERVICE AIDS

Insert service aids behind this page.



DIAGNOSTIC PROGRAMS

Diagnostic programs are provided for online testing of the 1442-5, 6, and 7. These routines are part of the diagnostic program package for the processing unit to which the 1442 is attached.

Detailed information about these diagnostic programs is included in the maintenance and/or programming manuals supplied with the processing unit.

CE SWITCH

The CE toggle switch, on the 1442 power supply panel, controls AC power to the drive motor and power supplies. When the switch is set at CE MODE, these offline maintenance procedures can be performed:

1. All static SRP mechanical adjustments.
2. Replacement of all mechanical parts, except lights and switches.

CAUTION: Replacement of light and key receptacles requires removal of system power from the 1442.

LAMP TEST

A lamp test line in the 1442 indicator lamp circuits gives the customer and the CE a quick method of detecting burned out indicator lamps. When this line is activated from the processing unit, all lamps on the 1442 are activated.

DATA PULSE SWITCH

This rotary switch connects various signal lines to an adjacent hub. This allows the selected line to be more readily observed on a scope. The lines that can be selected are:

1. Each of the 12 read data pulses.
2. Read emitter.
3. Punch card lever.
4. Feed CB 1.
5. Feed CB 2.
6. Punch CB 1.

A second hub provides Feed CB 1 as a sync point.



CHAPTER III. PREVENTIVE MAINTENANCE
PROCEDURES

APPROACH TO SCHEDULED MAINTENANCE

The purpose of scheduled maintenance is to improve machine operation and reduce the amount of down-time. Details of maintenance operations are listed in the scheduled maintenance routine chart (Figure 3-1). Only the operations listed for a certain period

of time should be done. Suggested frequency is based on 173 hours per month usage, or 250,000 feed operations.

Visual inspection should be the first step of every maintenance operation. Correction of noticeable corrosion, dirt, wear, binds, burned contacts, and loose parts helps prevent future problems.

CODE		UNIT	FREQ	OPERATION	OBSERVE	PAGE
U	R					
8		Clutch	3	LUBRICATE CARD FEED CLUTCH Grease fitting - IBM 23 (Grease until excess shows) <u>Wipe off excess.</u> LUBRICATE READ CLUTCH Grease fitting - IBM 23 (Grease until excess shows) <u>Wipe off excess.</u>		
7		Feed	6	LUBRICATE CARD FEED CLUTCH COMPONENTS Clutch sleeve arm - IBM 23 Guides for shock mounted section of clutch latch (old style)- IBM 23 Clutch latch pivot bushing (new style) - IBM 6 End of clutch latch - IBM 23 Top of keeper - IBM 23 Input bearing of card feed clutch shaft - IBM 23 LUBRICATE READ CLUTCH COMPONENTS Clutch sleeve arm - IBM 23 Guides for shock mounted section of clutch latch - IBM 23 End of clutch latch - IBM 23 Top of keeper - IBM 23 LUBRICATE CARD FEED COMPONENTS Card feed output shaft-cams - IBM 23 (Replace wipers if necessary) Stacker jogger connecting rods - IBM 6 Pickerknife drive idler pulleys - 2 places with IBM 6 Hopper pressure feed roll hanger bearings - IBM 6 Hopper empty switch lever bearings - IBM 6 Stacker cornering station bell crank contact surfaces - IBM 23 Anti-backup mechanism - IBM 23 Needle bearing - card feed clutch shaft - IBM 6 Gears - NYLATRON* and steel - 5 places with IBM 23 NOTE: <u>Do not lubricate read nudge roll gear train.</u>		

*Trademark of Polymer Corp., Reading, Pa.

• Figure 3-1. Preventive Maintenance Routine Chart (Part 1 of 2)

CODE		UNIT	FREQ	OPERATION	OBSERVE	PAGE
U	R					
1		Feed	6	CLEAN Base Card transport Emitter disk slots Read head asm mask Fiber bundle ends Read emitter phototransistors	CHECK Read and card feed clutch response Read emitter timing Light source lamp adjustment	4-1 4-2 4-6
4		Punch	6	CLEAN Punch magnet hold coil	CHECK Punch magnet hold coil voltage adjustment	4-6
2		Feed	9	LUBRICATE Pickerknife cam and cam followers - IBM 23 Read nudge pressure roll pivot - IBM 6 Read eject pressure roll pivot - IBM 6 Pickerknife pivots - 2 places with IBM 6		
6		Punch	9	LUBRICATE Punch Cam - replace wick Restore asm cam - replace wick Interposer cam - IBM 23 on wick Interposer pivots - 12 places with IBM 6 - <u>avoid dripping.</u> Incremental drive eccentric - replace wicks Gears - 4 places with IBM 24 Punch bail block - IBM 23 Incremental drive ratchet - IBM 24 Incremental drive pawls - 2 places with IBM 6 Restore asm pivots - 24 places with IBM 6 (avoid dripping) Incremental drive cam - 2 places with IBM 23 Leaf springs (interposers and restore levers) 36 places with IBM 24 Incremental drive latch pivot - 2 places with IBM 6		3-3
5		Drive Mech. & Misc	9		CHECK Cables and wiring for loose terminals and overheated insulation. Belts and pulleys for significant wear or damage.	

● Figure 3-1. Preventive Maintenance Routine Chart (Part 2 of 2)

Lubrication diagrams (Figures 3-2 and 3-3) reference the parts of the punch unit and incremental drive that require lubrication. Use the PM Chart to determine frequency; use the lubrication diagram to assist in determining where to lubricate and what lubricant to use.

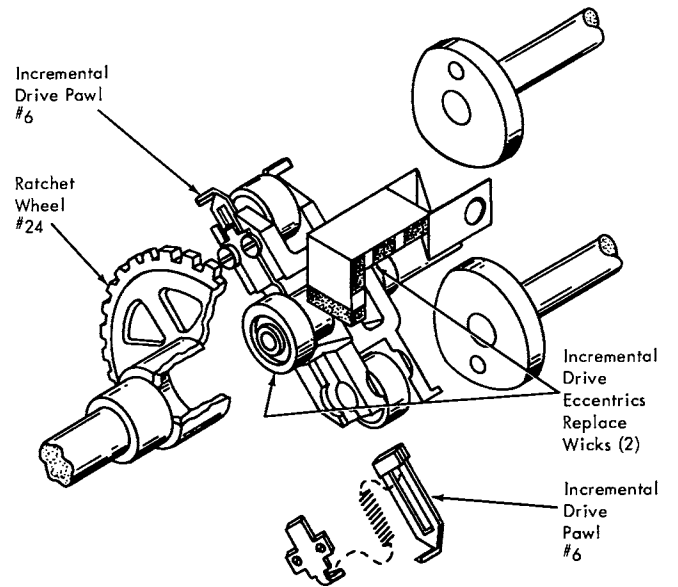

Figure 3-3. Incremental Drive Lubrication

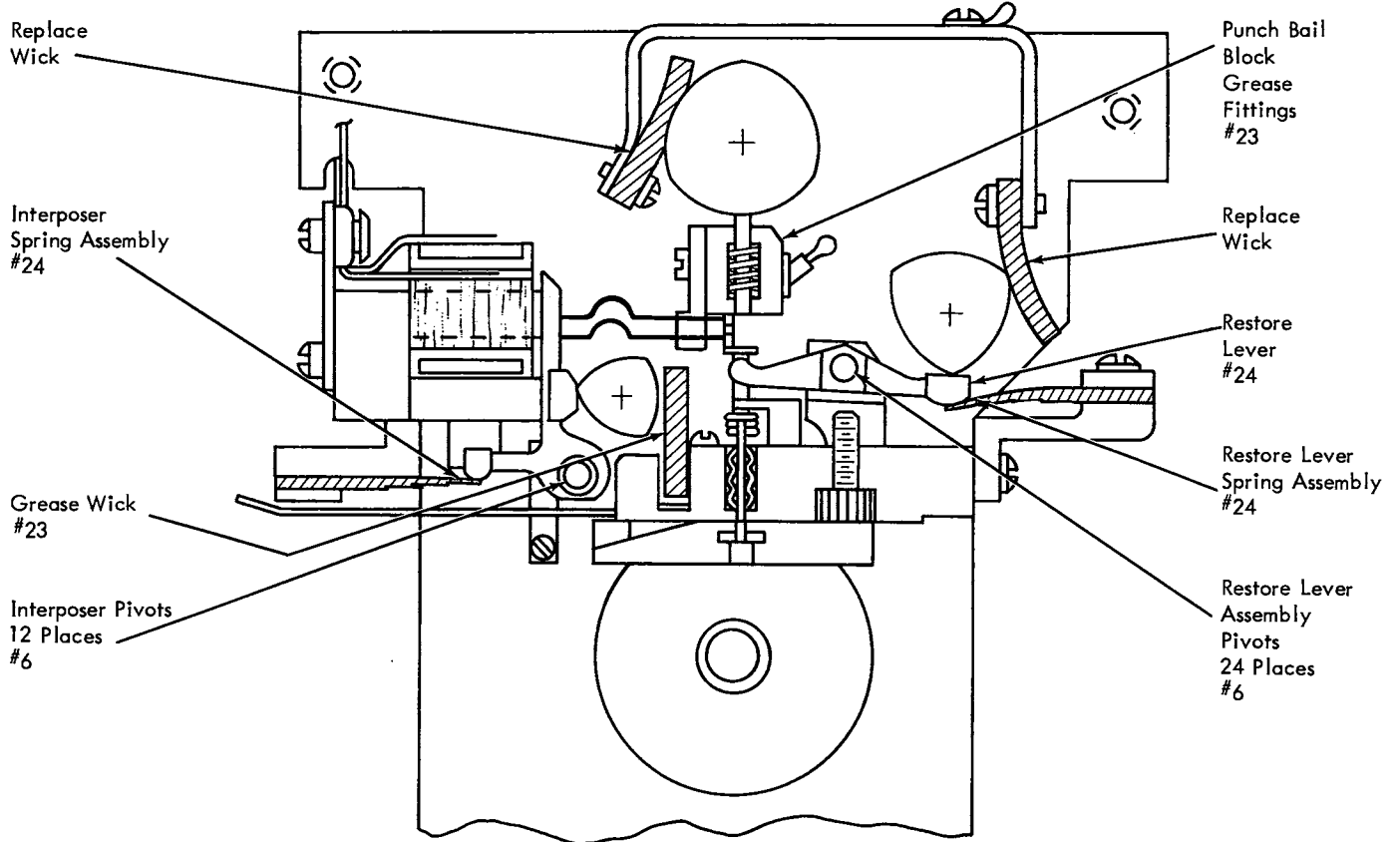
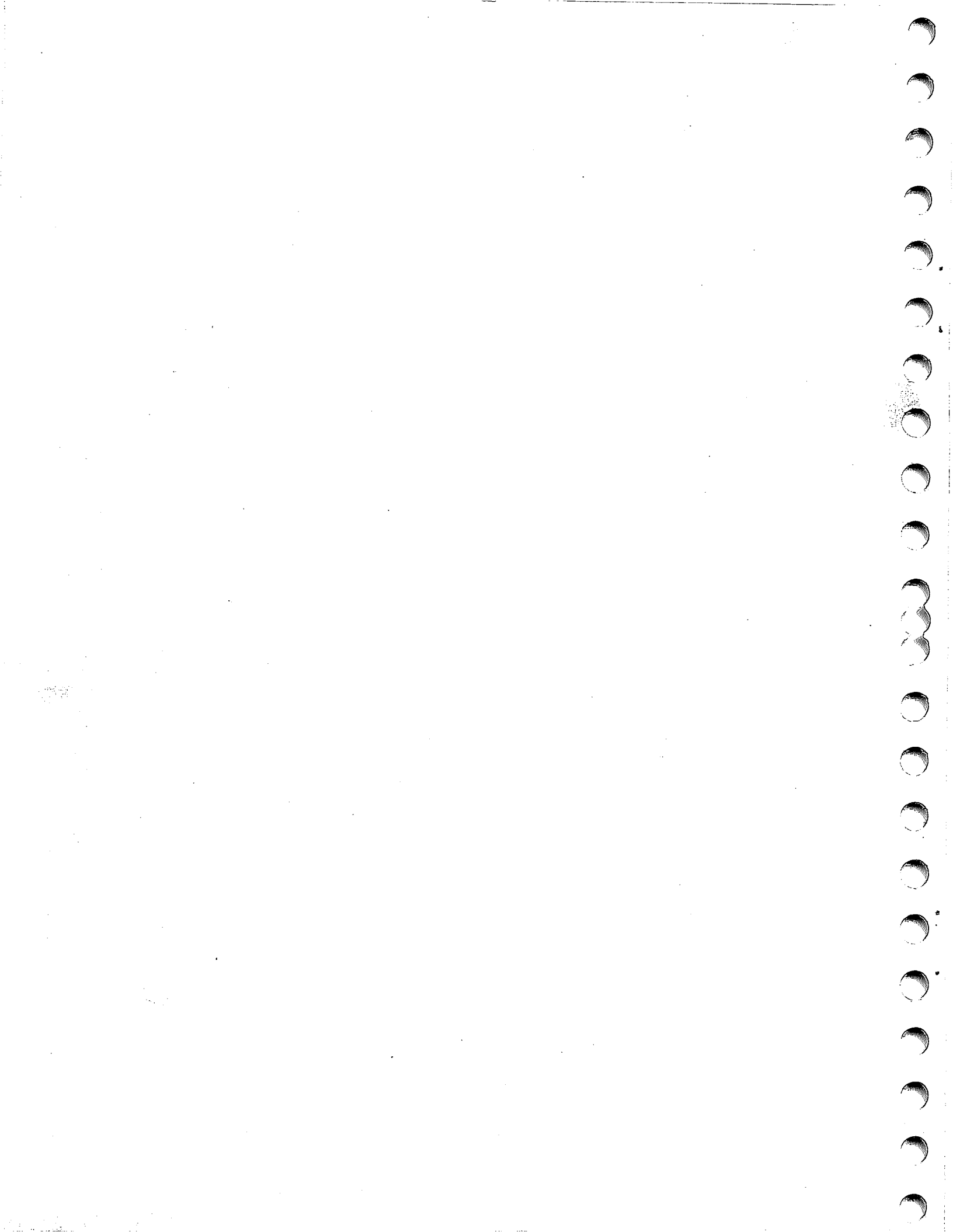

Figure 3-2. Punch Unit Lubrication



MECHANICAL ADJUSTMENTS AND REMOVALS

The check, adjustment, and removal procedures for mechanical units of the Serial Reader Punch (SRP) not provided in this section are provided in the IBM Field Engineering Maintenance Manual, Serial Reader Punch, Form 231-0026.

CARD FEED CLUTCH RESPONSE SERVICE CHECK

Objective

Check clutch operation by determining the time required for the clutch to engage after the clutch magnet is energized.

Procedure

1. Sync scope: — Feed Clutch Select (ER 181).
2. Observe output of Feed CB 1 (ER 101).
3. Initiate clutch operations by momentarily depressing the NPRO key.
4. Feed CB 1 line should become active at about 17 to 24 milliseconds after the sync. Actual time varies between machines because of differing machine speeds. However, the timing on successive cycles should not vary more than 2.0 milliseconds.
5. Failure to obtain the timing in step 4 may be caused by one or more of the following:
 - Incorrect adjustment of control sleeve-to-latch arm clearance.
 - Contamination.
 - Lack of lubrication.
 - Helical spring incorrectly installed.

READ CLUTCH RESPONSE SERVICE CHECK, MODELS 6 AND 7

Objective

Check overall clutch operation by determining the time required for the clutch to engage after it is mechanically activated.

Procedure

1. Sync scope on Feed CB 1 line (ER 101).
2. Observe + Read Emitter line (ER 131).
3. Use the NPRO key to run the machine without cards.
4. The first emitter pulse should go plus at between 7 and 11 milliseconds after the sync. Actual time varies because of differing machine speed and emitter adjustment. With the NPRO key held down, the start of the first emitter pulse should vary no more than 500 usec between cycles.
5. Failure to obtain the timing in step 4 may be caused by one or more of the following:
 - Incorrect adjustment of control sleeve-to-latch arm clearance.
 - Contamination.
 - Lack of lubrication.
 - Weak or defective helical spring.
 - Binding control sleeve.

NOTE: Defective components cannot always be visually detected. If adjustment and lubrication do not correct response problems, replace clutch spring.

Redesigned clutch components being used on current production machines help minimize response problems. These redesigned components are installed on machines shipped after 10/1/65 (approx.).

READ DATA PULSE SERVICE CHECK, MODELS 6 AND 7

Objective

Check for correct operation of read station.

Procedure

1. Set up 1442 to continuously read a deck of cards prepunched (all punches) in column 40. This can be done by programming or by placing both leads to the hopper switch on one terminal and using the NPRO key.
2. While running cards continuously, scope inputs and outputs of phototransistor amplifiers (ER 121, 131) and check:
 - a. 1442 Model 6
 - Minimum amplitude of any part of any data pulse from phototransistors should not be low enough to cause shortened output from amplifier (see Figure 4-9).
 - Data pulses should begin within 100 usec of each other.
 - b. 1442 Model 7
 - Minimum amplitude of any part of any data pulse from phototransistors should not be low enough to cause shortened output from amplifier (see Figure 4-9).
 - Data pulses should begin within 75 usec of each other.

If data pulses do not meet these specifications, check read station adjustments (SRP Maintenance Manual) and light source lamp voltage adjustment (this chapter).

READ EMITTER TIMING AND DURATION MODELS 6 AND 7

For convenience, two decks of cards should be available: one prepunched with all punches in column one, the other prepunched with all punches in column 40. These decks must be punched in accurate registration.

Service Check

Read emitter failures can be caused by an accumulation of dirt on the read emitter disk. This area should be cleaned frequently with a clean, dry brush. Check the operation of the read emitter by following the adjustment procedure, checking for the required conditions, without altering adjustments.

Adjustment Objectives

- Emitter pulse caused by first slot in emitter disk should occur during column one read time.
- Emitter pulse should begin 65 usec \pm 40 usec before the center of the data pulse for Model 6; 50 usec \pm 40 usec before the center of the data pulse for Model 7.
- Inactive time of emitter pulse should be 400 usec \pm 200 usec for Model 6; 300 usec \pm 150 usec for Model 7.

NOTE: Double traces, or a wide and a narrow pulse, will be seen when scoping the output of the read phototransistor amplifiers. The narrow pulse is the data pulse; the wide pulse is caused by the space between cards.

Adjustment Procedure

DANGER: Set the CE switch at CE MODE or unplug the drive motor cord before making mechanical adjustments to the emitter disk. This prevents the drive motor from being accidentally started.

Before making this adjustment, make certain that the timing (read pusher adjustment) and duration of the read pulses are within specifications, and that the read and card feed clutch response times are correct according to the procedure in Chapter IV.

1. Set up machine to continuously read a deck of cards prepunched (all punches) in column 1. Do this by programming or by placing both wires to the hopper switch on one terminal and operating the NPRO key.
2. Scope the output of the read emitter amplifier (Figure 4-1) and check that the off (inactive) time of the pulse is 400 usec \pm 200 usec for Model 6; 300 usec \pm 150 usec for Model 7.

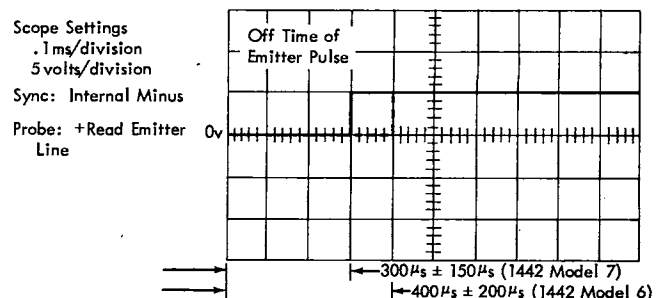

Figure 4-1. Read Emitter Inactive Duration

If time is incorrect, perform the read emitter mechanical adjustments described in the SRP maintenance manual. If this does not correct problem, perform the light source lamp voltage adjustments in this chapter.

3. Scope the output of one of the read photocell amplifiers and mark on the scope face the position of the column 1 data pulse (Figure 4-2).
4. Scope the output of the emitter amplifier. Adjust the position of the emitter disk until the first emitter pulse is about in the center of the column 1 data pulse (Figure 4-3).
5. Remove deck of cards prepunched in column 1 and replace with deck prepunched in column 40. Run this deck continuously.
6. Move the scope to the processing unit of the using system. Using internal sync, scope the + Any Lamp Dark line (Logic page XR221 for 1131; logic page EN761 for 1801). Adjust the time base of the scope so that the minus pulse caused by the punch in column 40 completely fills the scope face (Figure 4-4). (The narrow minus pulse is caused by column 40; the wide pulse is caused by the space between cards.)
7. Without changing the time-base setting, sync the scope external minus on the + Any Lamp Dark line and scope the + Read Emitter line (logic page XR301 for 1131; logic page EN521 for 1801). Adjust the read emitter eccentric

(and emitter disk if necessary) for one of the following conditions (Figure 4-5):

- a. 1442-6. Emitter pulse should begin 65 usec \pm 40 usec before the center of the data pulse (center of scope face).
- b. 1442-7. Emitter pulse should begin 50 usec \pm 40 usec before the center of the data pulse (center of scope face).

CARD FEED EMITTER

DANGER: Set the CE switch at CE MODE or unplug the drive motor cord before making mechanical adjustments to the emitter disk. This prevents the drive motor from being accidentally started.

Service Check

1. Manually trip CF clutch and crank machine until CF index reads 15°.
2. Check that the magnet on index disk lines up with upper emitter coil core (CB 1).
3. Check for .005" to .009" clearance between magnet and coil core.

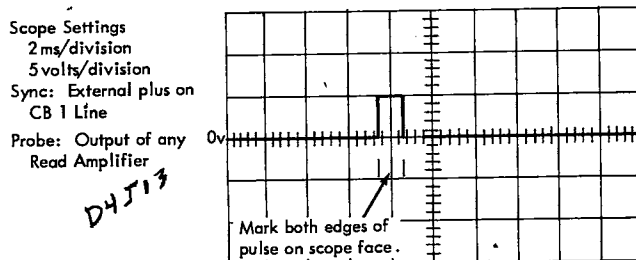

Figure 4-2. Marking Column One Data Pulse

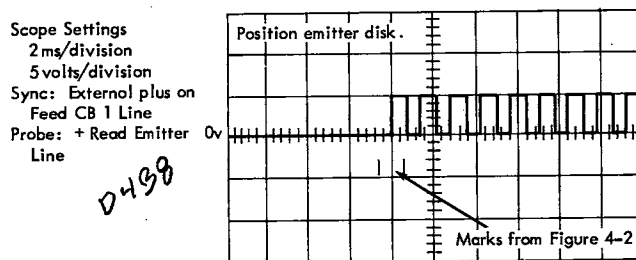

Figure 4-3. Adjusting First Emitter Pulse

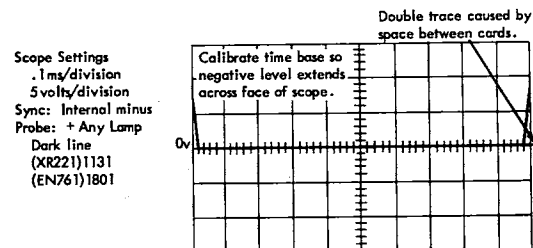

Figure 4-4. Setting All-Cells Pulse to Fill Scope Face

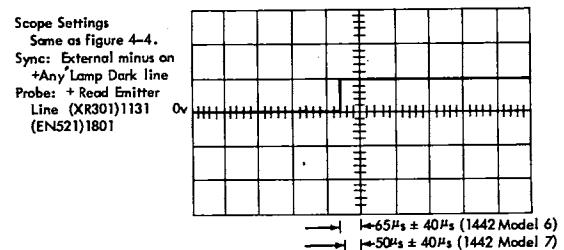

Figure 4-5. Final Emitter Setting

Adjustment Objectives

- CF CB pulses should occur at specified times (Figure 4-6).
- Coil core-to-emitter disk clearance should be .005" to .009" for all coils.

Adjustment Procedure

1. Manually trip CF clutch and crank machine until magnet on CF index lines up with upper emitter coil core (CB 1).
2. Loosen emitter coil lock screw (Figure 4-6).
3. Adjust coil for .005" to .009" clearance between coil core and magnet.
4. Tighten emitter coil lock screw.
5. Advance magnet to next coil and repeat steps 2, 3, and 4.
6. Perform step five for remaining coils.

PUNCH EMITTER

DANGER: Set the CE switch at CE MODE or unplug the drive motor cord before making mechanical adjustments to the emitter disk. This prevents the drive motor from being accidentally started.

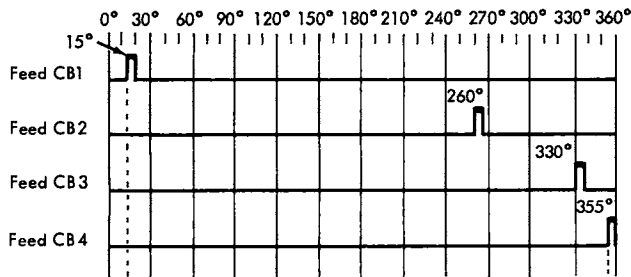
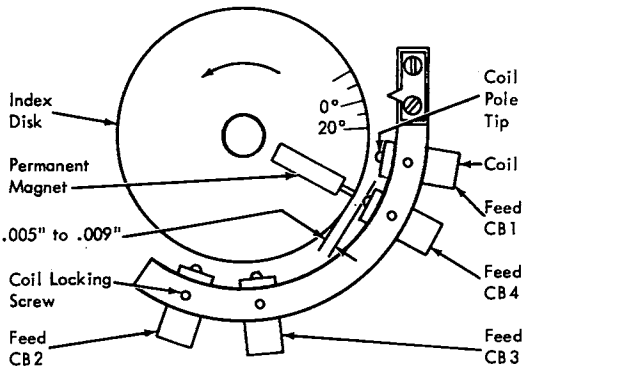

Figure 4-6. Feed CB Emitter Adjustment

Adjustment Objectives

- Emitter pulses should occur at the times shown on logic pages TC002 (1442-5 and 7) or TC003 (1442-6).
- Emitter pulse duration should be between 0.1 ms and 1.0 ms.

Adjustment Procedure

Before making this adjustment, make sure the interposer magnet assembly is properly adjusted (see SRP Maintenance Manual).

1. Loosen screw on front end of punch camshaft (Figure 4-7).
2. Crank machine until punch unit index is at 27° + 1° - 0° for Models 5 and 7; 36° ± 1° for Model 6.
3. Align one of the magnets on the punch emitter disk (Figure 4-7) with the upper coil core (Punch CB 1) and tighten screw on front of punch camshaft.

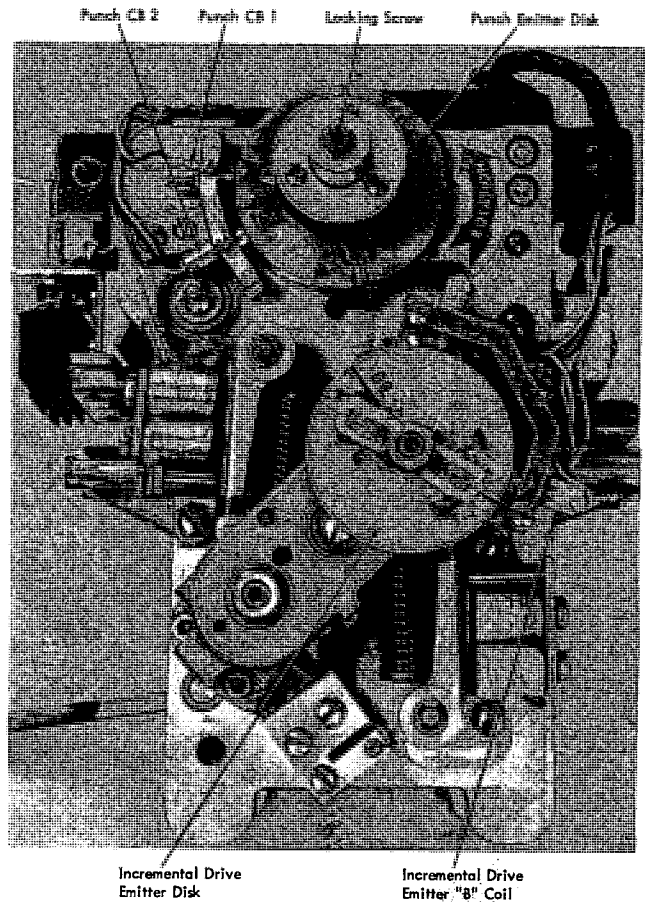

Figure 4-7. Punch and Incremental Drive Emitters

4. Set up the 1442 to run continuously.
5. Scope the outputs of the punch emitter amplifiers and adjust the coil core-to-emitter disk clearance of each coil for a pulse duration of 0.1 ms to 1.0 ms.

INCREMENTAL DRIVE EMITTER

DANGER: Set the CE switch at CE MODE or unplug the drive motor cord before making mechanical adjustments to the emitter disk. This prevents the drive motor from being accidentally started.

Adjustment Objectives

- Incremental drive emitter amplifiers should emit impulses at times shown on logic pages TC002 (1442-5 and 7) and TC003 (1442-6).
- Pulse duration should be 0.1 ms to 1.0 ms.

Adjustment Procedure

The incremental drive unit must be in time with the punch unit before making these adjustments.

1. Loosen nut on incremental drive emitter shaft (Figure 4-7).
2. Crank machine until punch index is at 0°; the A latch arm should be free to move (Figure 4-8).
3. Insert timing pin in punch unit timing disk (Figure 4-8, insert A).
4. Adjust position of emitter disk:
 - a. 1442-5 and 7. Align one of the magnets on the disk with the B (lower) coil (Figure 4-8, insert B).
 - b. 1442-6. Align scribed line on the emitter disk with B (lower) coil (Figure 4-8, insert C).
5. Tighten nut on incremental drive emitter shaft and remove timing pin.

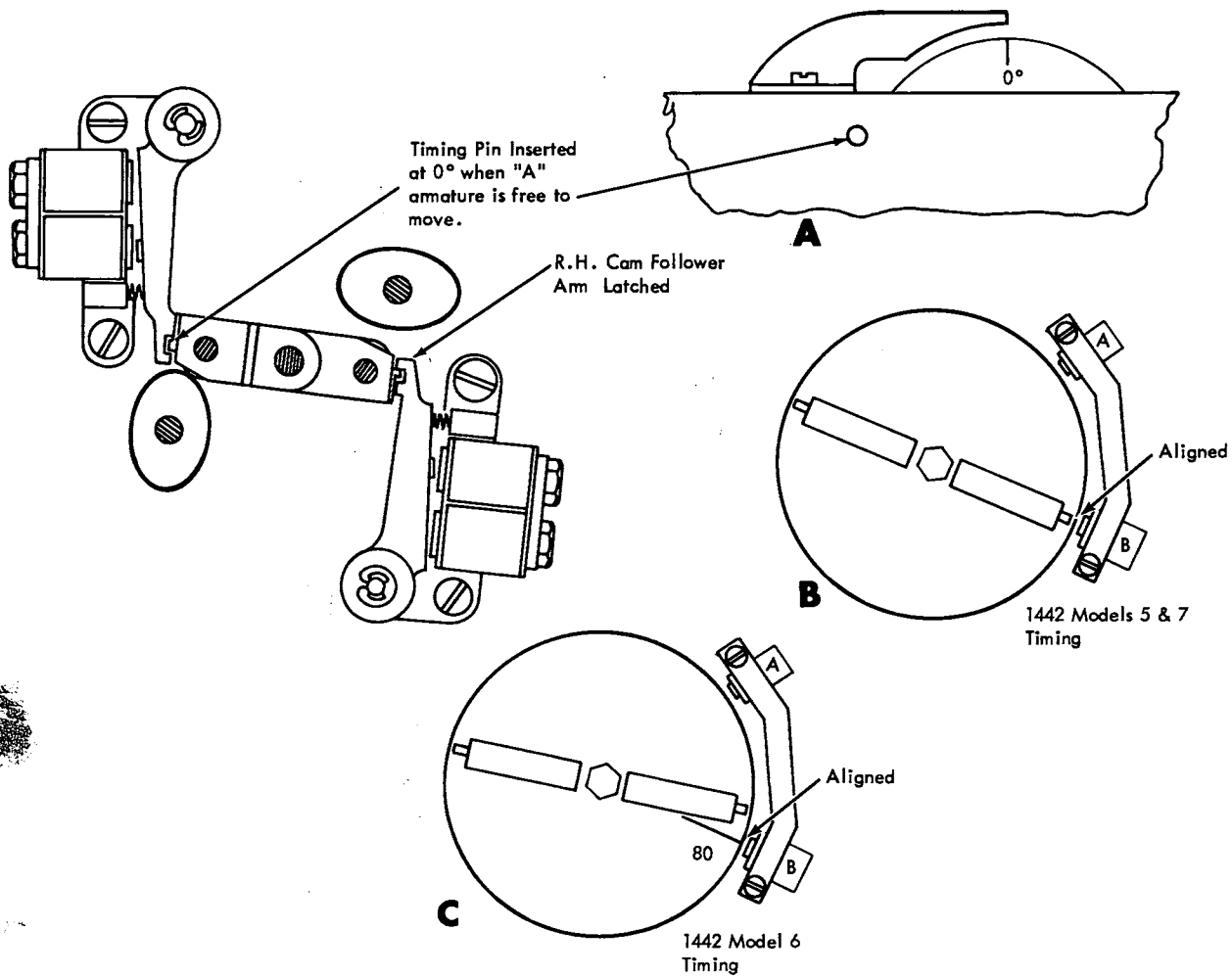

Figure 4-8. Incremental Drive Emitter Timing

6. Set up 1442 for continuous running.
7. Scope outputs of emitter amplifiers, and adjust coil-to-emitter disk clearance of coils A and B for pulse durations of 0.1 ms to 1.0 ms.

PUNCH HOLD COIL VOLTAGE

Adjustment Objective

Set the punch hold coil voltage at its optimum setting, halfway between the lower limit (where extra punches occur) and the upper limit (where punches are dropped).

Adjustment Procedure

NOTE: Hold coil voltage readings should not be taken while punching is taking place.

1. Attach meter across punch hold coil at TB 2, logic page YA 100.
2. Program system to punch heavy bit pattern (at least three punches) in all 80 columns of each card.
3. While punching this bit pattern, adjust the hold coil voltage potentiometer clockwise until punches start dropping. Stop the machine and measure the hold coil voltage at this point. This is the upper voltage limit.

NOTE: The potentiometer may go to its upper limit of travel without dropping punches. If this happens, record the highest voltage obtained as the upper limit voltage.

CAUTION: Do not lower the hold coil voltage below 6 volts.

4. While punching the same bit pattern, adjust the hold coil voltage potentiometer counterclockwise until extra punches occur (not below 6 volts). Stop the machine and measure the voltage. This is the lower limit voltage.

NOTE: The difference between the upper and lower limit voltages must be at least 2 volts. If this range cannot be obtained, check the interposer magnet assembly adjustments as described in the SRP Maintenance Manual.

5. Set the punch hold coil voltage midway between the upper and lower limit voltages. This point must be between 7.5 and 8.5 volts.

LIGHT SOURCE LAMP VOLTAGE, MODELS 6 AND 7

Adjustment Objective

Set the light source lamp voltage at its optimum setting. This provides the best possible performance from the read station while providing the longest practical lamp life.

Adjustment Procedure

The AC voltage applied to the lamp is adjusted by a potentiometer and a hi-lo range toggle switch, located on the rear of the power supply. The AC voltage applied to the lamp can be measured at the lamp terminal block.

NOTE: When scoping data pulses, a relatively long pulse, caused by the space between cards, will be observed during each feed cycle. When reading cards punched only in column 40, this results in a long and a short pulse, the short pulse being the data pulse. When reading blank cards, only the long pulse will appear.

CAUTION: Before switching the hi-lo range switch from LO to HI, rotate the potentiometer fully counterclockwise to prevent applying excessive voltage to the lamp.

1. Measure and record the AC voltage applied to the lamp.
2. Set up the 1442 to continuously read cards. This can be done by programming or by placing both leads to the hopper switch on one terminal and operating the NPRO key.
3. Find the lower-limit voltage:
 - a. Feed continuously a deck of manila-colored cards prepunched (all punches) in column 40.
 - b. Scope inputs to all data pulse amplifiers (ER 121, 131). Determine which amplifiers receive input waveforms with the lowest amplitude, and which amplifiers receive input waveforms with the highest amplitude (Figure 4-9).
 - c. Scope the output of the amplifier receiving the lowest amplitude waveform. Decrease lamp voltage until the data pulse length at the amplifier output decreases sharply (Figure 4-9). The lowest portion of the input waveform should now be about 0.5 to 0.7 volts.
 - d. Scope the output of the read emitter amplifier (ER 131). If no output is observed, increase lamp voltage until emitter pulses are observed.

- e. Measure the voltage applied to the lamp and record it as the lower-limit voltage.
 4. Find the upper-limit voltage:
 - a. Feed continuously a deck of blank manila-colored cards.
 - b. Scope the output of the data pulse amplifier previously determined to have the highest amplitude input waveform (step 3-b). Increase lamp voltage until extraneous spikes appear at the amplifier output, indicating that the "shine through" point has been reached.
 - c. Scope the output of the read emitter amplifier (ER 131). If the amplifier is found to be continuously on, decrease lamp voltage until read emitter pulses appear.
 - d. Measure the voltage applied to the lamp and record it as the upper limit voltage.
 5. Check that the difference between the lower and upper-limit voltages is at least 1.0 volt.
 6. Adjust the lamp voltage to $0.6v \pm 0.1v$ above the lower-limit voltage. The final voltage setting must not exceed 4.0 volts.
- If lamp voltage cannot be adjusted to meet specifications in steps 5 and 6, check the adjustment of the fiber bundles and light source as described in the SRP Maintenance Manual.
7. If the new voltage setting differs from the original setting (see step 1), check the read emitter timing adjustments described in this chapter.

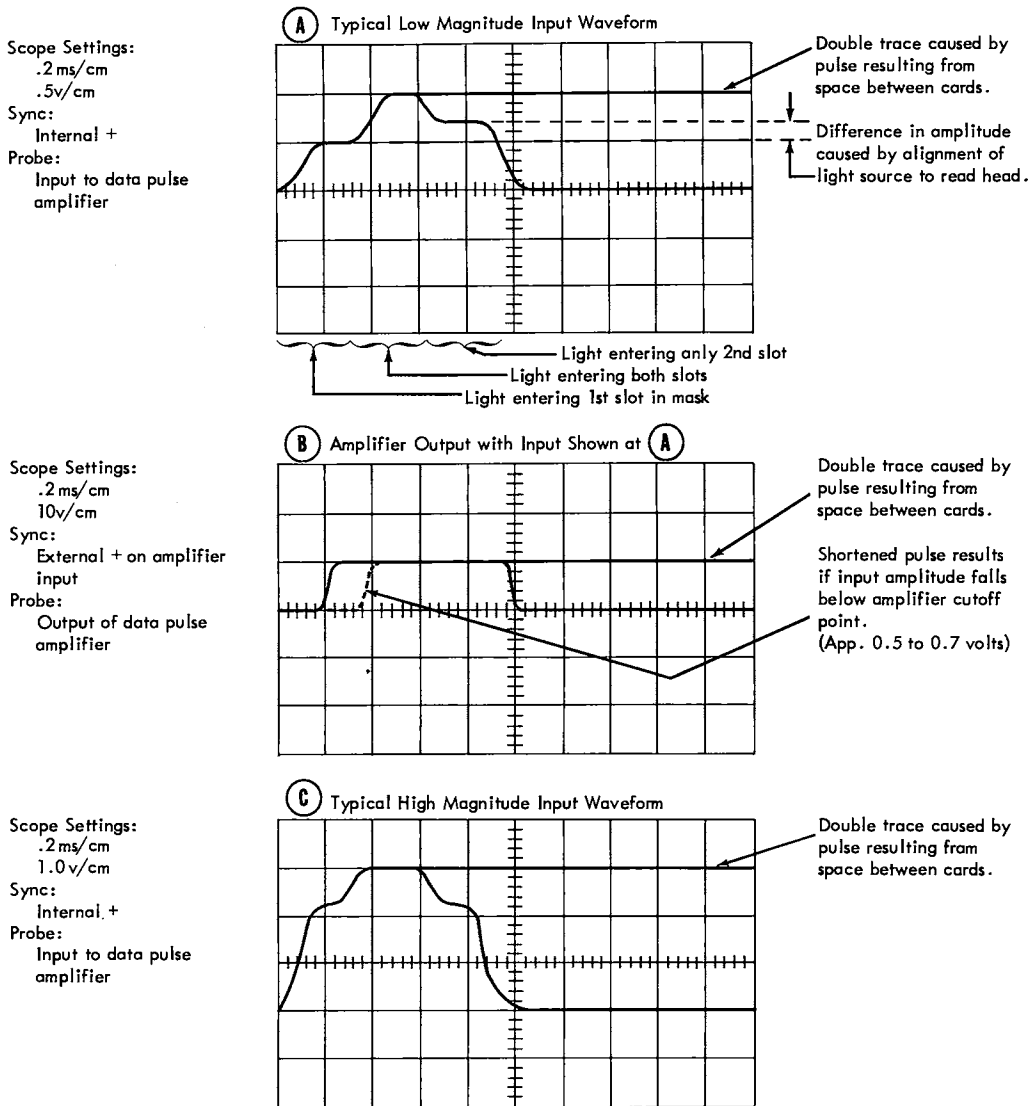

Figure 4-9. Data Pulse Waveforms

LIGHT SOURCE LAMP VOLTAGE, MODEL 5

Adjustment Objective

Set light source lamp voltage at its optimum setting to ensure the best performance and provide the longest practical lamp life.

Adjustment Procedure

The AC voltage applied to the lamp is adjusted by a potentiometer and a hi-lo range toggle switch, located on the rear of the power supply. The AC voltage applied to the lamp can be measured at the lamp terminal block.

CAUTION: Before switching the hi-lo range switch from LO to HI, rotate the potentiometer fully counterclockwise to prevent applying excessive voltage to the lamp.

1. With no card in the read station, observe the output of both the data 11 and the punch card lever amplifiers, logics ER 121 and ER 131 (use meter or scope).

2. Lower the lamp voltage until the output of one of the amplifiers switches off (down level).
3. Measure and record the AC voltage applied to the light source lamp. This is the lower limit.
4. Place a manila card between the light source and phototransistor of both the 11 read position and the punch card lever.
5. Raise the lamp voltage until one of the amplifiers switches on (up level). Do not exceed five volts.
6. Measure and record the AC voltage applied to the light source lamp. This is the upper limit.
7. If the difference between the upper and lower limits is less than one volt, set the lamp voltage midway between the limits. If the difference is greater than one volt, set the lamp voltage 0.6 v above the lower limit. The final setting must not exceed 4.0 volts.

Power Supply

(Reference YA 100)

Specifications

Input: 115/208/230 vac $\pm 10\%$ at 60 CPS $\pm 1/2$ CPS
Outputs: +12 vdc $\pm 15\%$
4.25 vac $\pm 7\%$
Regulation: Ferro-resonant transformer
Maximum Output Ripple: 3% P-P

Adjustments

The basic +12 vdc output is not adjustable in the field. The 115 vac, 208 vac, or 230 vac primary voltage is selected by connecting the primary voltage to the correct taps on terminal block TB 1.

The +12 vdc supplied to the punch hold coil at terminal TB2-7 is adjustable by a potentiometer.

The 4.25 vac supplied to the light source lamp at terminals TB2-3, 4 is adjustable by hi-lo switch SW1 and potentiometer R9.

Use Meter Transformer

Specifications

Input: 115/208/230 vac at 60 CPS
Output: 41 vac
Regulation: None

Adjustment

The 115, 208, or 230 vac primary voltages is selected by connecting the primary voltage to the correct taps on the transformer terminal block.



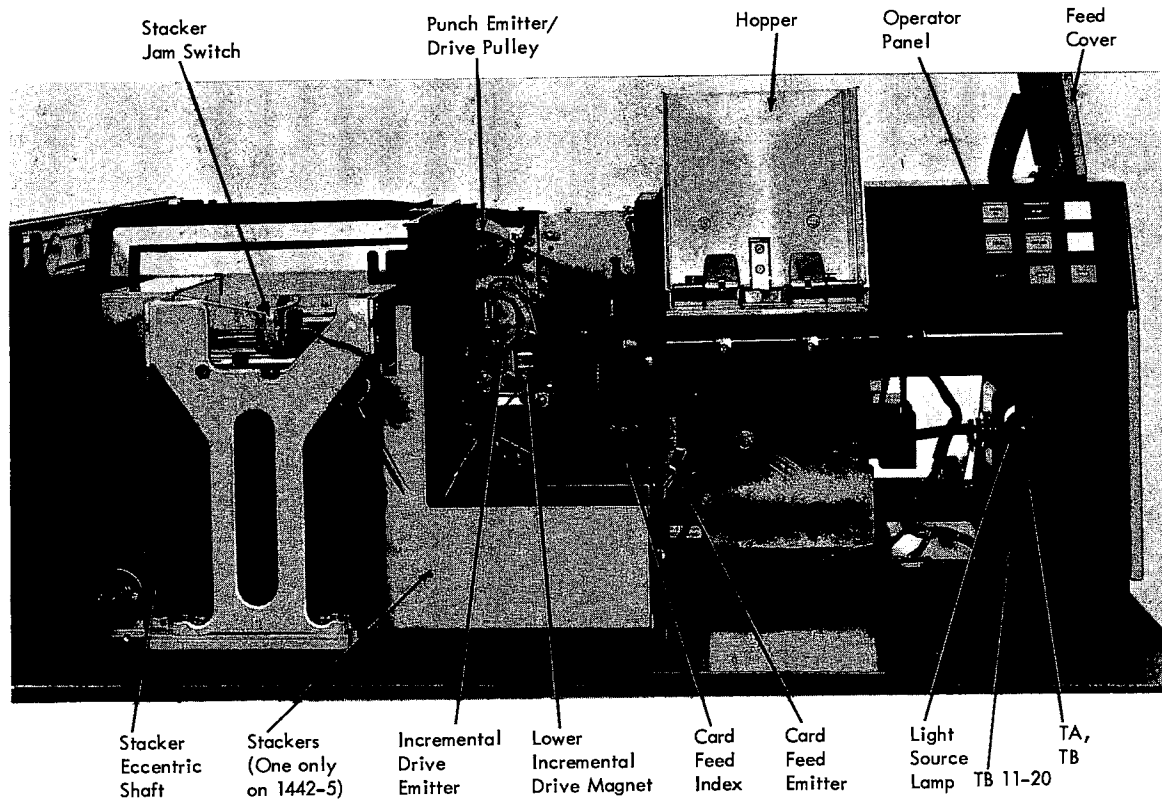

● Figure 6-1. IBM 1442 Models 5, 6, and 7 Locations (Above Base, Front View)

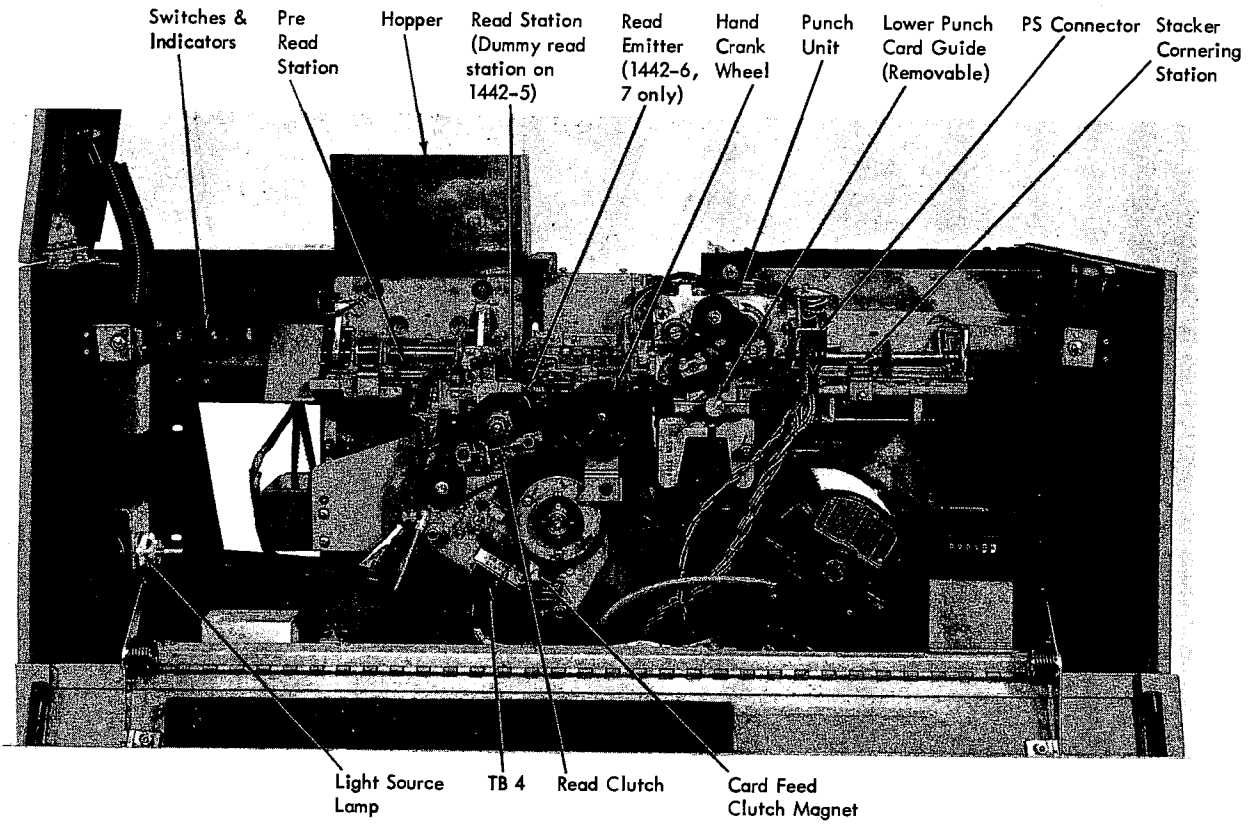
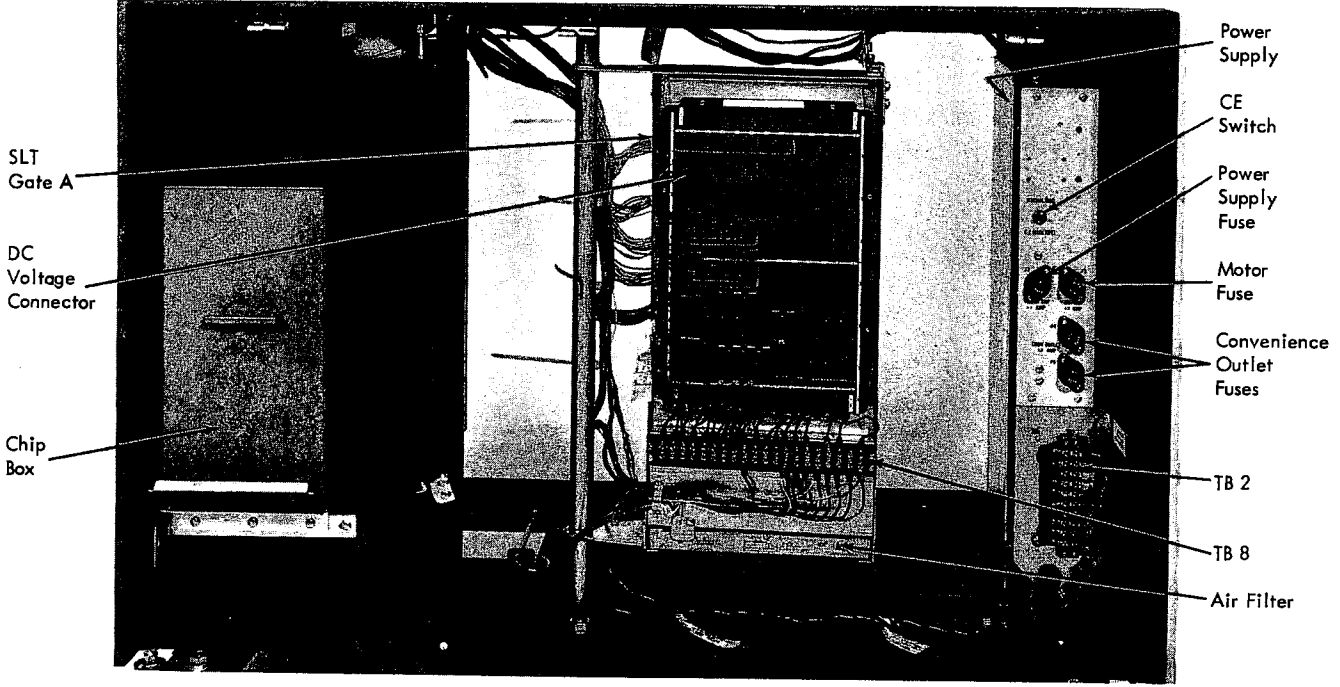
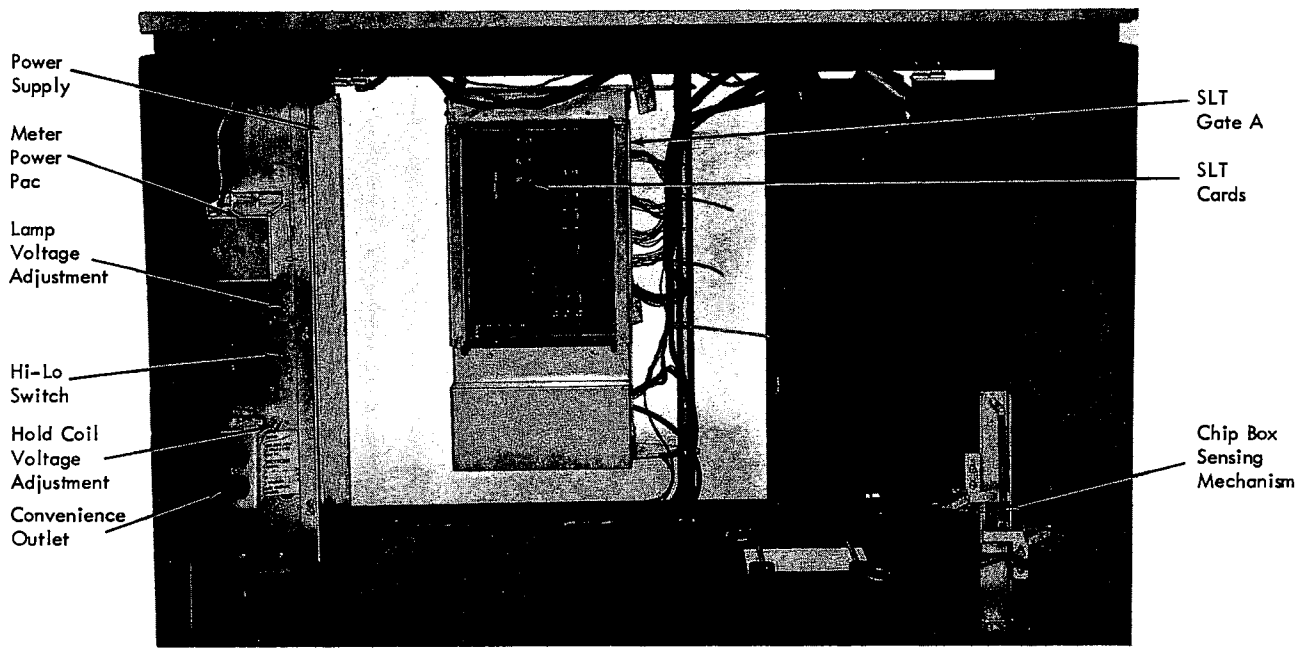

Figure 6-2. IBM 1442 Models 5, 6, and 7 Locations (Above Base, Rear View)



● Figure 6-3. IBM 1442 Models 5, 6, and 7 Locations (Below Base, Front View)



● Figure 6-4. IBM 1442 Models 5, 6, and 7 Locations (Below Base, Rear View)



- Adjustments 4-1
 - Card Feed Emitter 4-3
 - Incremental Drive Emitter 4-5
 - Light Source Lamp Voltage (Mods 6 & 7) 4-6
 - Light Source Lamp Voltage (Mod 5) 4-8
 - Power Supplies 5-1
 - Punch Emitter 4-4
 - Punch Hold Coil Voltage 4-6
 - Read Emitter Timing and Duration (Mods 6 & 7 Only) 4-2
 - Use Meter Transformer 5-1
- Approach to Scheduled Maintenance 3-1
- Attention Indicator 1-1
- Card Examination 1-1
- Card Feed Clutch Response Service Check 4-1
- Card Feed Emitter Adjustment and Service Check 4-3
- Card Nicking or Marking 1-1
- CE Switch 2-1
- Check Indicator 1-1
- Checks 4-1
 - Card Feed Clutch Response 4-1
 - Read Clutch Response (Mods 6 & 7 Only) 4-1
- Chip Box Indicator 1-1
- Data Pulse Service Check 4-2
- Diagnostic Aids 1-1
- Diagnostic Programs 2-1, 1-1
- Diagnostic Techniques 1-1
 - General Procedures 1-1
 - Card Examination 1-1
- Emitter (Card Feed) Adjustment and Service Check 4-3
- Emitter (Incremental Drive) Adjustment 4-5
- Emitter (Punch) Adjustment 4-4
- Emitter (Read) Timing and Duration Adjustment and Service Check (Mods 6 & 7 Only) 4-2
- Error Indicator Lamps 1-1
- Error Indications, Operator Console 1-1
- Errors, Reading 1-1
- Feed Clu (Clutch) Indicator 1-2
- General Diagnostic Procedures 1-1
- Hold Coil Voltage Adjustment 4-6
- Hopper Indicator 1-1
- Incremental Drive Emitter Adjustment 4-5
- Indicator Lamps 1-1
- Indicators, Error 1-1
- Inspection 3-1
- Lamp Test Line 2-1
- Lamp Voltage (Light Source)
 - Mod 5 Adjustment 4-8
 - Mods 6 & 7 Adjustment 4-6
- Lamps, Indicator 1-1
- Light Source Lamp Voltage
 - Mod 5 Adjustment 4-8
 - Mods 6 & 7 Adjustment 4-6
- Locations 6-1, 6-2, 6-3
 - Models 5, 6, & 7 Above Base Front 6-1
 - Models 5, 6, & 7 Above Base Rear 6-2
- Maintenance Features 2-1
- Marking Cards 1-1
- Mechanical Adjustments and Removals 4-1
- Nicking Cards 1-1
- Offline Maintenance 2-1
- Operator Console Error Indications 1-1
- Overrun Indicator 1-2
- PM Procedures 3-1
 - Power On Indicator 1-1
 - Power Supplies 5-1
 - Power Supply Adjustments 5-1
 - Mod 5 5-1
 - Mods 6 & 7 5-1
 - Power Supply Specifications 5-1
 - Mod 5 5-1
 - Mods 6 & 7 5-1
 - Punch Emitter Adjustment 4-4
 - Punch Hold Coil Voltage Adjustment 4-6
 - Punch Indicator 1-2
 - Punch Sta Indicator 1-2
 - Preventive Maintenance (PM) Procedures 3-1
 - Programs, Diagnostic 2-1, 1-1
- Read Clutch Response Service Check 4-1
- Read Data Pulse Service Check 4-2
- Read Emitter Timing and Duration Adjustment and Service Check 4-2
- Read Reg (Registration) Indicator 1-2
- Read Sta (Station) Indicator 1-1
- Reading Failures 1-1
- Ready Indicator 1-1
- Response Service Check 4-1
 - Card Feed Clutch 4-1
 - Read Clutch 4-1
- Scheduled Maintenance 3-1
- Sense Sta (Station) Indicator 1-2
- Service Aid Index 1-3
- Service Aids 1-5
- Service Checks
 - Card Feed Clutch Response 4-1
 - Card Feed Emitter 4-3
 - Read Clutch Response 4-1
 - Read Data Pulse Duration 4-2
 - Read Emitter Timing and Duration 4-2
- Specifications
 - DC Power Supplies 5-1
 - Use Meter Transformers 5-1
- Switch, CE 2-1
- Trans (Transport) Indicator 1-2
- Use Meter Transformers 5-1



READER'S COMMENT FORM

IBM 1442 - 5, 6, & 7 FE Maintenance Manual

Form Y31-0098-1

- Your comments, accompanied by answers to the following questions, help us produce better publications for your use. If your answer to a question is "No" or requires qualification, please explain in the space provided below. All comments will be handled on a non-confidential basis.

- | | Yes | No |
|--|---|--------------------------|
| ● Does this publication meet your needs? | <input type="checkbox"/> | <input type="checkbox"/> |
| ● Did you find the material: | | |
| Easy to read and understand? | <input type="checkbox"/> | <input type="checkbox"/> |
| Organized for convenient use? | <input type="checkbox"/> | <input type="checkbox"/> |
| Complete? | <input type="checkbox"/> | <input type="checkbox"/> |
| Well illustrated? | <input type="checkbox"/> | <input type="checkbox"/> |
| Written for your technical level? | <input type="checkbox"/> | <input type="checkbox"/> |
| ● What is your occupation? _____ | | |
| ● How do you use this publication? | | |
| As an introduction to the subject? <input type="checkbox"/> | As an instructor in a class? <input type="checkbox"/> | |
| For advanced knowledge of the subject? <input type="checkbox"/> | As a student in a class? <input type="checkbox"/> | |
| For information about operating procedures? <input type="checkbox"/> | As a reference manual? <input type="checkbox"/> | |
| Other _____ | | |
| ● Please give specific page and line references with your comments when appropriate.
If you wish a reply, be sure to include your name and address. | | |

COMMENTS:

- Thank you for your cooperation. No postage necessary if mailed in the U.S.A.

fold

fold

BUSINESS REPLY MAIL
NO POSTAGE NECESSARY IF MAILED IN THE UNITED STATES

FIRST CLASS
PERMIT NO. 387
ROCHESTER, MINN.



POSTAGE WILL BE PAID BY . . .

IBM Corporation
Systems Development Division
Development Laboratory
Rochester, Minnesota 55901

Attention: Product Publications, Dept. 245

fold

fold